



Congratulations and Welcome!

Whether this is your first time changing tires, or you're a seasoned mechanic, take the first step to mastering the No-Mar technique now and visit our Video Library to view our latest instructional videos:



NoMarTireChanger.com

Our Video Library is the single most important resource available for:

- Tire Changer Assembly
- Tire Changing Technique ("How To...")
- Avoiding Common Mistakes ("How NOT To...")
- Keeping Wheels Scratch-Free
- Saving Money by Maximizing Consumable Life





Classic® HD Motorcycle Tire Changer Assembly Introduction

Assembly Preparation

We recommend unpacking and assembling your tire changer in the following order:

1. Box **A** - Mount/Demount Bar (save 5/32" Hex ("Allen") Wrench for use with Box **D**).
2. Box **B** - Stand Assembly
3. Box **C** - Frame Assembly
4. Box **D** - Upper Arm Assembly

Each of the sub-assembly boxes noted above has its own set of instructions included.

Assembly Notes and Tips:

1. All set screws (sometimes called "grub" screws) and select other screws have been pre-installed in their specified locations at the factory to aid in identification and assembly. Remaining hardware needed for assembly is included in the hardware pack inside of Box **C**.
2. Some screws may be more difficult than others to turn in due to excess powder coating residue in the threads. In these cases, a drop of oil or other lubricant (such as WD-40®) can aid in installation, as well as partially tightening and then loosening gradually until the screw is completely fastened.
3. We **strongly** recommend using only the provided Hex ("Allen") Wrenches to install/tighten hex-drive screws, and hand tools (ratchet or combination wrench) for other bolts. Using power tools (even battery powered) can cause threads to strip or hex sockets to round out.

Tools Required for Assembly:

- 5/32" Hex (Allen) Wrench - Included in Lube Box inside of Box **A**
- 3/16" Hex (Allen) Wrench - Included inside of Box **E**
- 3/4" (or 19mm) Wrench - Socket w/Ratchet, Combination or similar
- 7/16" (or 11mm) Wrench - Socket w/Ratchet, Combination or similar
- 1/2" (or 13mm) Wrench - Socket w/Ratchet, Combination or similar

For mounting your Tire Changer to the floor, we recommend using 1/2" x 3+1/2" (or 12mm x 100mm) Concrete Wedge anchors (Power-Stud+® SD1 or similar) drilled to a minimum depth of 2+3/4" (or 70mm) and installed per manufacturer directions with nuts and washers.

Help & Support

If you have any difficulty assembling your tire changer or changing tires, the instructional videos on our website are extremely thorough and helpful (and are also the primary method of learning how to change your own motorcycle tires). We also have an extensive Frequently Asked Questions (FAQ) page on our website for common tire changing issues.

If you require further assistance or technical support, please call us at 888-98-NOMAR (888-986-6627) and we will be happy to assist you!



Classic® HD Stand Box 'B' Assembly Instructions

Hardware Pack Contents:

- a. (18) 1" Flat Cap Screw
- b. (16) Serrated Flange Nut
- c. 3/16" Hex ("Allen") Wrench



Figure 1

Note: If you are installing your Classic HD® Tire Changer on our Hitch Mount instead of a Stand Post, you may disregard these instructions.

Step 1:

Remove all items from the box. Using the provided 3/16" Hex Wrench and a 1/2" (13mm) wrench, attach the Stand Base Square to the Stand Post using (8) 1" Flat Cap Screws and (8) Serrated Flange Nuts. The Flat Cap Screws should be installed from the Base Square into the Stand Post so that the nuts will be on the top of the Stand Post flange (See Figure 1).

The screws attaching the Stand Base to the Stand Post will not sit completely flush with the bottom of the Stand Base and this is by design.

Step 2:

Using the provided 3/16" Hex Wrench and a 1/2" (13mm) wrench, attach the Stand Triangle to the Stand Post using (8) 1" FSHCS and (8) Serrated Flange Nuts. Orient the parts so that the rear "point" of the triangle is aligned with the vertical tab on the Stand Post, and so that nuts will be on the bottom of the Stand Post flange (See Figure 1).

The Flat Cap Screws attaching the Stand Triangle to the Stand Post will not sit completely flush with the top of the Stand Triangle and this is by design.

Congratulations, your Stand Post assembly is complete! Keep all tools handy and proceed to assemble tire changer frame Box C.

(Note: The vertical tab on the Stand Post may be used for ground-level bead breaking with the addition of our ground-level bead breaking upgrade kit available on our website.)



Classic® HD Frame Box 'C' Cycle Hill® HD Plus Frame Box 'G' Assembly Instructions

Hardware Pack Contents:

a. (12) 1/2" Flat Cap Screw



b. (3) 1" Hex Bolt



c. (3) Flat Washer



d. (1) Shoulder Bolt*



e. (1) Nylock Nut*



(*Shoulder Bolt and Nylock Nut (parts 'd' and 'e') are only included with Classic® HD models or with waist-high bead breaking upgrade.)

Step 1:

Remove all items from the box and remove any wrapping/strapping from components in the box.

Step 2:

Attach all 3 Frame Arms together using 2 "Y-plates" as shown. The bottom Y-plate has a welded cup, and the top Y-plate has an open hole. Using the 3/16" Hex Wrench from the stand box, install 6 Flat Cap Screws (a) on top and 6 screws (a) on bottom (leave screws loose until all 12 screws are threaded in place). The single threaded boss on each frame arm must face downward. Note the orientation of the left frame arm as indicated by the wheel size decal. Tighten screws in an alternating pattern from the inside to outside.

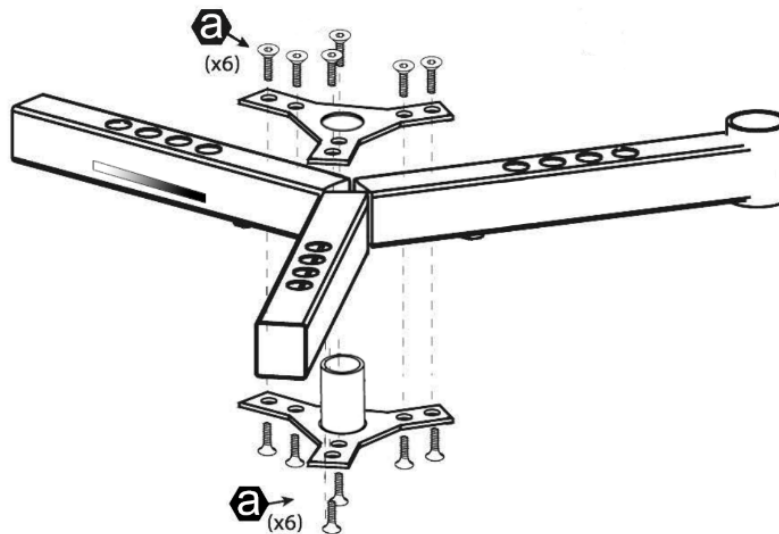

Step 3:

Place the completed frame arm assembly on the triangle of the Stand Post or Hitch Mount and align the three holes in the triangle with the three threaded bosses on the frame arm assembly (the frame arm with the welded collar is the rear frame arm and should be aligned with the rear "point" of the triangle).

Step 4:

Install a Flat Washer (c) on each of the 3 Hex Bolts (b). Thread each Hex Bolt with Flat Washer through holes in the Stand Post or Hitch Mount triangle into the threaded boss on each frame arm by hand. Once all 3 Hex Bolts are started, tighten with a 3/4" (19mm) wrench.

Step 5:

Install wheel clamps on to the frame arms. For Classic® HD models, install the locking Cam Block (the block with the handle pre-installed) in the right front frame arm, and 2 Dog Blocks in the left front and rear frame arms. The Dog Block in the rear frame arm should be installed in the hole marked with a Yellow dot or laser-cut hole on the side of the frame arm indicating the proper position for waist-high bead breaking.

Congratulations, your Frame assembly is complete! Keep any remaining unused parts and all tools handy and proceed to assemble the Upper Arm (Box D or J depending on model).



Classic® HD Upper Arm Box 'D' **Assembly Instructions**

Hardware Pack Contents:

- a. (1) Female T-Knob
- b. (1) 3" Carriage Bolt
- c. (1) Flat Washer



Step 1:

Remove all items from the box and remove any wrapping/strapping from components in the box. Have the 5/32" Hex ("Allen") Wrench from Box 'A' handy.

Step 2:

Orient Back Post with Aluminum Tee so that it is upside-down (protect powder coat finish on aluminum tee by resting on cardboard, carpet or other soft surface).

Step 3:

Identify the Rear of the Back Post. Approximately 1/2" inch (13mm) from the edge of the aluminum tee there will be a set screw installed in the Back Post tube. This set screw identifies the rear of the Back Post.

Step 4:

Install Tool Collar on to Back Post. Make sure that the two bent tangs for holding the Mount/Demount Bar are facing down, towards the Aluminum Tee. Orient the tool collar so that the collar is aligned to the rear of the Back Post and the two set screws to secure the Back Post are on the front side of the Back post. Tool Collar should be up against the bottom of the aluminum tee by gravity only (do not push tightly together). Tighten the two set screws in the Tool Collar using the 5/32" Hex Wrench.

Step 5:

Install Clevis Collar (from Box 'K') on Back Post so it is up against Tool Collar by gravity only.

Step 6:

Install the Stop Collar (from Box 'C') on Back Post so it is up against Clevis Collar by gravity only. Tighten the two set screws on the Stop Collar.

Step 7:

Compare Back Post configuration to photo to ensure components are arranged correctly:





Classic® HD Upper Arm Box 'D' Assembly Instructions

Step 8:

Pick up Back Post and turn right-side-up so the Aluminum Tee is on top. Install bottom of Back Post into rear Frame Arm of tire changer so that there is 4 inches of Back Post exposed from the bottom of the frame arm collar (see photo).

Rotate the Back Post so that the Tool Collar is aligned to the rear of the tire changer. Tighten the 4 set screws on the rear frame arm collar to secure the Back Post in position.



Never configure Back Post with less than 4 inches exposed below the rear frame arm collar as this risks damage to tire changer and personal injury!

Step 9:

Remove the shoulder bolt and two washers from the Clevis Collar using the 5/32" Hex Wrench. Orient the Waist High Bead Breaker Arm so that the larger of the two tubes is on top, and the tab with the hole on the end is facing the tire changer. Carefully install the front tab of the Break Arm into the Clevis Collar with one washer on each side of the Break Arm. Re-install the shoulder bolt and tighten.

Step 10:

Attach Bead Breaker "Tee" to the Bead Breaker Arm using 1/2" Shoulder Bolt (d) and Nylock Nut (e) from Box 'K'. Verify proper alignment of the tee so that the curve of the tee aligns with the curve on a wheel. There will be some play to this joint once tightened, and this is by design. We recommend installing the ATV Tee (the one without protective plastic wedges as shown in Figure 1 of the Stand Assembly instructions) on the stand post bead breaker arm for ground-level bead breaking, and the Scratch-Proof Bead Breaker Tee on the waist-height bead breaker arm. The Bead Breaker assembly may now be rotated off to the right and out of the way.

Step 11:

Install the rear of the Slide Arm into the Aluminum Tee. The front of the slide arm has the knob which you will orient on the right side during installation. Depending on powder coat thickness, a rubber mallet may be needed to get the slide arm into position. Align the large hole in the slide arm with the cup in the center of the frame assembly.



Step 12:

Install the Carriage bolt (b) in the left side of the Aluminum Tee (the square hole), then install the flat washer (c) and T-Knob (a). Tighten the T-Knob hand-tight only; there is no need to over-tighten and doing so will damage the T-Knob.



Classic® HD Upper Arm Box 'D' Assembly Instructions

Step 13:

Install the Center Post through the large hole in the Slide Arm with the non-marring bushing and axle pin facing down. Tighten the T-Knob on the side of the Slide Arm to secure the Center Post in place. *(Note when changing tires, the Center Post will not completely go through most axle bearings – that is what the eccentric pin and non-marring bushing are for. Engage the pin in the bearing with the bushing to protect the bearing seal. The pressure from the pin against the bearing while changing a tire is far less than the pressures exerted on the bearing when installed on a bike.)*



Congratulations, your Upper Arm assembly is complete and your tire changer is almost ready to use! Once your tire changer is securely mounted to the floor or our Hitch Mount, you're ready to change tires! Ride safe!



Space Requirements

